

# Energy Efficient 3 Phase LV Induction Motors



Catalogue 2018

- Inverter Duty Motors
- Crane Duty Motors
- Brake Motors



# About us

Havells India Ltd is a billion-dollar-plus organization, and is one of the largest & India's fastest growing electrical and power distribution equipment manufacturer with products ranging from Industrial & Domestic Circuit Protection Switchgear, Cables & Wires, Motors, Fans, Power Capacitors, CFL Lamps, Luminaires for Domestic, Commercial & Industrial applications, Modular Switches, & Bathfittings covering the entire gamut of household, commercial and industrial electrical needs.

Havells owns some of the prestigious global brands like Crabtree, Sylvania, Concord, Luminance, Linolite, & SLI Lighting.

With 91 branches / representative offices and over 8000 professionals in over 50 countries across the globe, the group has achieved rapid success in the past few years. Its 11 state-of-the-art manufacturing plants in India located at Haridwar, Baddi, Noida, Sahibabad, Faridabad, Bhiwadi, Alwar, Neemrana, and 10 state-of-the-art manufacturing plants located across Europe, Latin America & Africa churn out globally acclaimed products. Havells is a name synonymous with excellence and expertise in the electrical industry.

To add to the existing state-of-the-art manufacturing plants, Havells has now started a world class Motor Plant at Neemrana (Rajasthan). It is one of the largest LV Motor Plant in Asia spread over 42 acres land and where we manufacture energy efficient motors ranging from 0.12HP to 470HP.

The plant has a capacity of manufacturing over 20000 motors per month. The state-of-the art plant and machinery has been imported from AEG Spain.

The Manufacturing Strengths of the Plant are :

- In house manufacturing of complete range of motors from 56-355 frame
- Automatic winding lines from 56-250 frame
- Automatic impregnation plant
- Vacuum impregnation plant
- Fully Automated temperature controlled paint stations
- Modern Automatic Type Test Plant
- Mechanical Test Lab

Havells is committed to manufacturing excellence and providing world class quality products at affordable prices. Havells offers a complete solution which is not only safe and reliable but also saves energy. We will continue the same tradition with our motors also.

## Contents

Type of Motors	Page
Inverter Duty Motors	3-4
Crane Duty Motor	5-9
Brake Duty Motor	10-14

## View of Motor Manufacturing Plant



## Manufacturing Process



CNC Machine



Rotor Balancing



Automatic Winding



Automatic Impregnation Plant



Assembly Line



Testing



Painting Line



# Inverter Duty Motors

(With Forced Cooling)



Havells manufactures squirrel cage inverter duty motors which are specially designed for operations requiring wide speed variation through variable speed drives. These motors are generally used when the motor is running for longer duration at speeds below 70% of rated name plate speed.

Inverter duty motors operate at constant torque upto rated design frequency when connected with variable frequency drives.

The motors are fitted with separate cooling arrangement which ensures that the motors perform successfully at lower speeds without over-heating of the motor. This also ensures that the loading capacity of the motor is not reduced in this range.

All external cooling fans are rated at 3000 rpm which provide excellent cooling to the motors even at lower speed of operation.

## Features

Voltage	:	3 Ph., 415 V Other voltage as per requirement
Frequency	:	50 Hz Other frequency as per requirement
Ambient	:	50 Deg. C
Ins. Class	:	F (Temp. rise Class B)
Range	:	0.37 kW to 55 kW
Pole	:	2, 4, 6 and 8 Pole
Frame	:	80 to 250
Frequency Range	:	20 to 75 Hz
Mounting	:	B3, B5, B14 and combination
Cooling	:	IC 416

Enclosure	:	Totally Enclosed Separately Cooled
Protection	:	IP 55
Standards	:	IS: 325, IS: 1231, IS: 2223 IS: 4722

## Deration Factor for Higher Ambient

Ambient temp.	Deration Factor
55 Deg. C	0.94
60 Deg. C	0.88

## Encoder Mounting

The motors are provided with encoder mounting arrangement as a standard feature which is required by customers for motor control.

The loadability curve of the motor is as shown below:

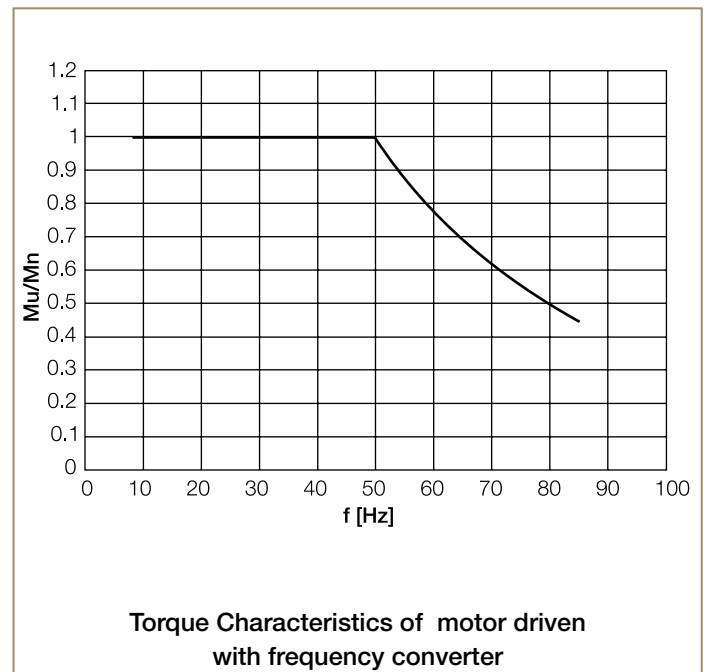

While selecting the motor, maximum allowed speed of the motor is also to be considered. For 2 pole motors, the maximum allowed speed is 4000 rpm and for 4 pole motors, it is 3600 rpm.

When the nominal supply voltage of the converter is more than 500 V, it is recommended to use du/dt filters which reduce voltage stresses in the winding by reducing the rate of change of phase and main voltages.

The use of converters with motors also demands extra requirements in terms of cabling and grounding of the drive system. Although asymmetrical cables can be used for the cabling but it is recommended to use shielded symmetrical cables along with EMC glands.



## Rating Chart

2 POLE			4 POLE			6 POLE			8 POLE		
FRAME	KW	H.P	FRAME	KW	H.P	FRAME	KW	H.P	FRAME	KW	H.P
MH 80Z AA 2	0.75	1	MH 80Z AA 4	0.55	0.75	MH 80Z AA 6	0.37	0.5	MH 80Z AA 8	0.25	0.33
MH 80Z BA 2	1.1	1.5	MH 80Z BA 4	0.75	1	MH 80Z BA 6	0.55	0.75	MH 90S AA 8	0.37	0.5
MH 90S AA 2	1.5	2	MH 90S AA 4	1.1	1.5	MH 90S AA 6	0.75	1	MH 90L BA 8	0.55	0.75
MH 90S BA 2	1.8	2.5	MH 90L BA 4	1.5	2	MH 90L BA 6	1.1	1.5	MH 100L AA 8	0.75	1
MH 90L CA 2	2.2	3	MH 100L AA 4	2.2	3	MH 100L AA 6	1.5	2	MH 100L BA 8	1.1	1.5
MH 100L AA 2	3	4	MH 112M AA 4	3.7	5	MH 112M AA 6	2.2	3	MH 112M AA 8	1.5	2
MH 100L BA 2	3.7	5	MH 132S ZA 4	5.5	7.5	MH 132S YA 6	3.7	5	MH 132S ZA 8	2.2	3
MH 112M AA 2	3.7	5	MH 132M ZA 4	7.5	10	MH 132M ZA 6	5.5	7.5	MH 160M YA 8	3.7	5
MH 132S YA 2	5.5	7.5	MH 160M YA 4	9.3	12.5	MH 160M ZA 6	7.5	10	MH 160M ZA 8	5.5	7.5
MH 132 S ZA 2	7.5	10	MH 160M XA 4	11	15	MH 160L YA 6	9.3	12.5	MH 160L ZA 8	7.5	10
MH 160M TA 2	9.3	12.5	MH 160L XA 4	15	20	MH 160L ZA 6	11	15	MH 180L YG 8	9.3	12.5
MH 160M VA 2	11	15	MH 180M XG 4	18.5	25	MH 180L ZG 6	15	20	MH 180L ZG 8	11	15
MH 160M XA 2	15	20	MH 180L XG 4	22	30	MH 200L PG 6	18.5	25	MH 200L RG 8	15	20
MH 160L XA 2	18.5	25	MH 200L NG 4	30	40	MH 200L RG 6	22	30	MH 225S P 8	18.5	25
MH 180M XG 2	22	30	MH 225S N 4	37	40	MH 225M P 6	30	40	MH 225M P 8	22	30
MH 200L LG 2	30	40	MH 225M N 4	45	60	MH 250M P 6	37	50	MH 250M P 8	30	40
MH 200L NG 2	37	50	MH 250M N 4	55	75						

**Note:-** For higher ratings, please refer our nearest marketing office

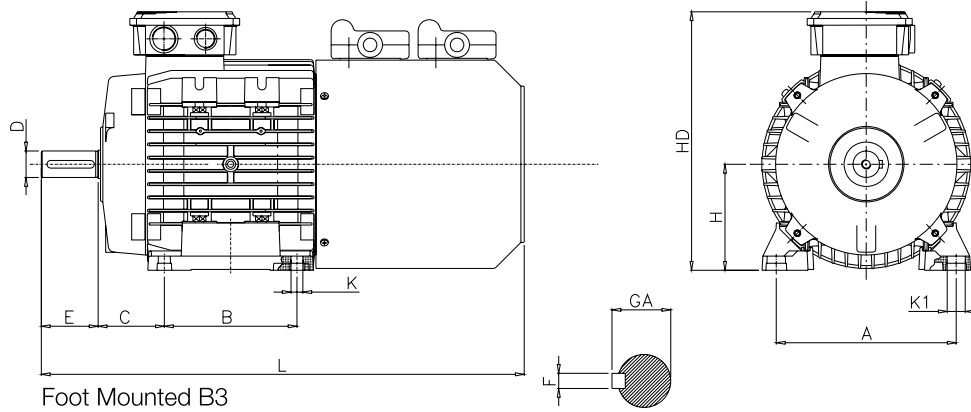

Frame	Pole	General Dimensions											
		D	E	F	L	GA	H	A	B	C	K	HD	K1
80	2-8	19 j6	40	6	366	21.5	80	125	100	50	10	219	14
90S	2-8	24 j6	50	8	550.5	27	90	140	100	56	10	238	15
90L	2-8	24 j6	50	8	550.5	27	90	140	125	56	10	238	15
100L	2-8	28 j6	60	8	589.5	31	100	160	140	63	11	255	17
112M	2-8	28 j6	60	8	514	31	112	190	140	70	12.5	283	19
132S	2-8	38 k6	80	10	570	41	132	216	140	89	12	327	20
132M	2-8	38 k6	80	10	629.5	41	132	216	178	89	12	327	20
160M	2-8	42 k6	110	12	716.5	45	160	254	210	108	14	400.5	18
160L	2-8	42 k6	110	12	780.5	45	160	254	254	108	14	400.5	18
180M	2-8	48 k6	110	14	797	51.5	180	279	241	121	14	470	18
180L	2-8	48 k6	110	14	797	51.5	180	279	279	121	14	470	18
200L	2-8	55 m6	110	16	909.5	59	200	318	305	133	18	541	18
225S	2	55 m6	110	16	951.5	59	225	356	286	149	18.5	585	19
	4	60 m6	140	18	981.5	64	225	356	286	149	18.5	585	19
225M	2	55 m6	110	16	951.5	59	225	356	311	149	18.5	585	19
	4	60 m6	140	18	981.5	64	225	356	286	149	18.5	585	19
250M	2	60 m6	140	18	1055	64	250	406	349	168	22	640	28
	4	65 m6	140	18	1055	69	250	406	349	168	22	640	28

**Note:** For other dimensions refer to Latest Havells Standard Motor Catalogue

# Crane Duty Motors



Havells India Ltd. Crane Duty Motors have been suitably designed for arduous applications for short and intermittent duties involving starts, stops and reversals.

These motors are used on applications like cranes, lifts, material handling, weirs and sluices and auxiliary motors in rolling mills.

Crane Duty motors are designed to have high starting torque with low starting currents. These characteristics ensure that the motors have high acceleration torques that are required in frequent start/ stop applications.

## Product Range

Frame	:	71- 160
kW/Hp	:	0.37 – 15 / 0.5 - 20
Pole	:	4-8 Pole
Mounting	:	Foot, Flange, Face and combination

## CE Marking

All motors have CE Marking.

## Operating Conditions

The standard operating conditions for the crane duty motors are:

Voltage	:	415 ± 10% Volts
Frequency	:	50 ± 5 % Hz
Combined	:	± 10 %
Ambient Temperature	:	45° C
Altitude	:	Upto 1000 m above mean sea level

In case any operating conditions are different than above, please contact nearest branch office of Havells India Ltd.

## Standards

The motors conform to the following standards

IS: 325	Three Phase Induction Motors- Specification
IS: 1231	Dimensions of Three Phase Foot Mounted Induction Motors

IS: 2223	Dimensions of Flange Mounted Induction Motors
IS: 4722	Rotating Electrical Machines- Specification
IS: 4691	Degree of Protection For Rotating Electrical Machines
IS: 6362	Designation of Methods of Cooling of Rotating Electrical Machines

## Electrical Design

### Winding

All crane duty motors are manufactured using dual coat class F copper wire (with temperature withstand up to 155°C) as standard.

### Insulation

The motors are having class F insulation with temperature rise limited to Class B. The motors are impregnated in a computerized impregnation plant that ensures high quality of impregnation with high varnish retention.

## Deration for Higher Ambient & Altitude

For selection of motors for higher ambient and altitude, the rated kW should be reduced by the following factors for the frame selection.

Ambient	45°C	50°C	55°C	60°C	
Factor	100%	95%	90%	80%	
Altitude	1000m	1500m	2000m	2500m	3000m
Factor	100%	95%	92%	88%	84%

## Intermittent Duty Application

The motors are designed for intermittent duty operations and different starts/stops per hour as shown in the rating charts.

The frame selections are based considering load GD2 values referred to motor shaft are less than or equal to motor GD2 values. Various intermittent duty types are explained below.

### Short Time Duty - S2 Duty

The motor operates at constant load for a given duration which is less than that required to reach thermal equilibrium and is followed by a rest or de-energized period such that the motor cools down to close to ambient temperature.

The recommended values for the short time duty are 10, 30, 60 and 90 minutes.

N = Operation at constant load  
 $\varnothing_{max}$  = Maximum temperature attained during the duty cycle

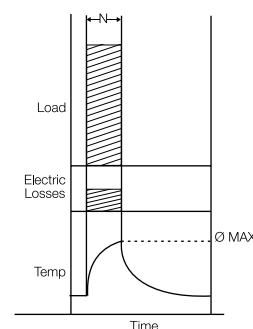

### Intermittent Periodic Duty with Starting- S3 Duty

The operation cycle consists of operation at constant load followed by a rest and de-energized period. The duty cycle is such that thermal equilibrium is not reached during one periodic cycle.

N = Operation at constant load

R = At rest and de-energized

Ømax = Maximum temperature attained during the duty cycle

$$\text{Cycle duration factor} = \frac{N}{N + R} 100\%$$

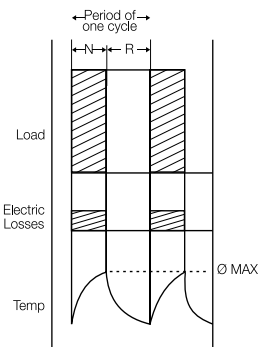

### Intermittent Periodic Duty with Starting- S4 Duty

In this duty cycle, each cycle consist of a period of starting, a period of operation at constant load followed by a rest and de-energized period. The duration of one cycle is so short that thermal equilibrium is not reached during one duty cycle.

D = Starting

N = Operation at constant load

R = At rest and de-energized

Ømax = Maximum temperature attained during the duty cycle

$$\text{Cycle duration factor} = \frac{D + N}{D + N + R} 100\%$$

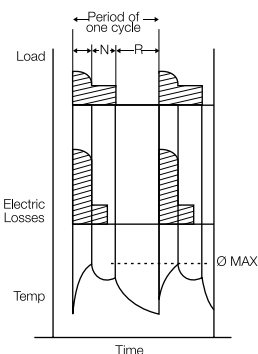

### Mechanical Design

#### Construction

Crane Duty Motors are available in Aluminum/ Cast Iron frames as per table below:

Frame	Body	End-Shield
71-90	Aluminum	Aluminum
100-132	Aluminum	Cast Iron
100-160	Cast Iron	Cast Iron

Frames 80 & 90 shall also be available in Cast Iron on request.

For higher frames, kindly refer to nearest branch office.

#### Enclosure

All motors are Totally Enclosed Fan Cooled (TEFC) as per IS 4691 and are suitable to operate in both outdoor and indoor applications.

#### Cooling

The motors are designed with IC0141 method of cooling as per IS 6362 which provides excellent heat dissipation of the motors and ensures longer life of the motor.

### Degree of Protection

Degree of protection for machines are designated in accordance with IS 4691 by letter IP followed by two characteristic numerals corresponding to protection from dust and water. All motors are provided with IP55 degree of protection as a standard and are suitable for operation in dusty and humid environment conditions.

### Bearing Details

All motors are fitted with deep groove ball bearings with C3 clearance and greased for life ensuring longer trouble free operation. The details of bearings used are given in the table.

Frame	Bearing DE/ NDE
71	6203- 2Z / 6203- 2Z
80	6204-2Z C3 / 6204-2Z C3
90	6205-2Z C3 / 6205-2Z C3
100	6206-2Z C3 / 6206-2Z C3
112	6306-2Z C3 / 6306-2Z C3
132	6208-2Z C3 / 6208-2Z C3
160	6309-2Z C3 / 6309-2Z C3

### Terminal Box

Terminal box is provided on top as a standard.

The details of Terminal Box and maximum cable size are shown in the table.

Frame	Max. Cable Size	No. of Terminals	Terminal Stud Size	Cable Entry	
				Nos.	Size
71	4C x 4 mm <sup>2</sup>	6	M4	2	M16 M20
80	4C x 4 mm <sup>2</sup>	6	M4	2	M20 M25
90	4C x 10 mm <sup>2</sup>	6	M5	2	M20 M25
100	4C x 10 mm <sup>2</sup>	6	M5	2	M20 M25
112	4C x 10 mm <sup>2</sup>	6	M5	2	M20 M25
132	4C x 10 mm <sup>2</sup>	6	M5	2	M32 M32
160	3C x 50 mm <sup>2</sup>	6	M6	2	M40 M40

### Information required at the time of enquiry

The following information should be provided at the time of enquiry.

1. Motor kW and Pole
2. Application
3. Supply voltage and frequency with variation
4. Ambient Temperature
5. Duty Type, CDF and number of starts/ stops per hour
6. Mounting arrangement
7. Load GD2 referred to motor shaft (If more than Motor GD2)
8. Degree of protection
9. Shaft extension, If other than standard
10. Any other relevant information

# Selection Chart

## Crane Duty Motors

(S2 / S3 / S4 Duty)

4 Pole (Speed 1500 RPM)

Frame	60 Starts / hour			90 Starts / hour			Motor GD <sup>2</sup> kGm <sup>2</sup> x10 <sup>-3</sup>
	25% CDF	40% CDF	60% CDF	25% CDF	40% CDF	60% CDF	
	kW	kW	kW	kW	kW	kW	
71ZCA4	0.55	0.55	0.55	0.55	0.55	0.55	3.92
80ZAA4	0.55	0.55	0.55	0.55	0.55	0.55	6.32
80ZBA4	0.75	0.75	0.75	0.75	0.75	0.75	8.0
80ZCA4	1.1	1.1	1.1	1.1	1.1	1.1	9.64
90SAA4	1.1	1.1	1.1	1.1	1.1	1.1	10.0
90LBA4	1.5	1.5	1.5	1.5	1.5	1.5	12.52
90LDA4	2.2	2.2	2.2	2.2	2.2	2.2	16.2
100LAA4	2.2	2.2	2.2	2.2	2.2	2.2	18.4
100LBA4	3.0	3.0	3.0	3.0	3.0	3.0	22.32
100LCA4	3.7	3.7	3.3	3.7	3.7	3.3	24.2
112MAA4	3.7	3.7	3.7	3.7	3.7	3.7	48.8
112MBA4	5.5	5.5	5.0	5.5	5.5	5.0	60.8
132SZA4	5.5	5.5	5.5	5.5	5.5	5.5	88.0
132MZA4	7.5	7.5	7.5	7.5	7.5	7.5	120
132MRA4	9.3	9.3	9.3	9.3	9.3	8.5	148.8
160MXA4	11	11	11	11	11	9.9	324.8
160LXA4	15	15	15	15	15	15	422.8

4 Pole (Speed 1500 RPM)

Frame	150 Starts / hour			300 Starts / hour			Motor GD <sup>2</sup> kGm <sup>2</sup> x10 <sup>-3</sup>
	25% CDF	40% CDF	60% CDF	25% CDF	40% CDF	60% CDF	
	kW	kW	kW	kW	kW	kW	
71ZCA4	0.55	0.55	0.5	0.5	0.45	0.4	3.92
80ZAA4	0.55	0.55	0.55	0.55	0.5	0.45	6.32
80ZBA4	0.75	0.75	0.75	0.67	0.6	0.6	8.0
80ZCA4	1.1	1.1	1.0	1.0	1.0	0.8	9.64
90SAA4	1.1	1.1	1.1	1.1	1.1	1.0	10.0
90LBA4	1.5	1.5	1.5	1.5	1.5	1.3	12.52
90LDA4	2.2	2.2	2.2	2.2	2.0	2.0	16.2
100LAA4	2.2	2.2	2.2	2.2	2.2	2.0	18.4
100LBA4	3.0	3.0	3.0	2.8	2.8	2.5	22.32
100LCA4	3.7	3.3	3.0	3.0	3.0	2.5	24.2
112MAA4	3.7	3.7	3.7	3.7	3.3	3.0	48.8
112MBA4	5.5	5.5	4.5	4.5	4.0	3.5	60.8
132SZA4	5.5	5.5	5.5	5.5	5.0	4.0	88.0
132MZA4	7.5	7.5	7.5	7.5	7.0	6	120
132MRA4	9.3	8.5	8.0	7.7	7.2	6.8	148.8
160MXA4	11	11	9.3	8.0	7.5	7.0	324.8
160LXA4	15	15	13.5	13.5	11	9.3	422.8

**Note:** 1. Load GD<sup>2</sup> value should not be more than motor GD<sup>2</sup> value. 2. All motors suitable for an Ambient Temperature of 45 deg. C.



# Selection Chart

## Crane Duty Motors

(S2 / S3 / S4 Duty)

6 Pole (Speed 1000 RPM)

Frame	60 Starts / hour			90 Starts / hour			Motor GD <sup>2</sup> kGm <sup>2</sup> x10 <sup>-3</sup>
	25% CDF	40% CDF	60% CDF	25% CDF	40% CDF	60% CDF	
	kW	kW	kW	kW	kW	kW	
80ZAA6	0.37	0.37	0.37	0.37	0.37	0.37	7.88
80ZBA6	0.55	0.55	0.55	0.55	0.55	0.55	9.88
90SAA6	0.75	0.75	0.75	0.75	0.75	0.75	12.72
90LBA6	1.1	1.1	1.1	1.1	1.1	1.1	19.12
100LAA6	1.5	1.5	1.5	1.5	1.5	1.5	26.92
100LBA6	1.8	1.8	1.8	1.8	1.8	1.8	37.72
112MAA6	2.2	2.2	2.2	2.2	2.2	2.2	56.72
112MBA6	3.0	3.0	3.0	3.0	3.0	2.7	74.8
132SZA6	3.0	3.0	3.0	3.0	3.0	3.0	94.0
132MYA6	3.7	3.7	3.7	3.7	3.7	3.7	118.0
132MZA6	5.5	5.5	5.5	5.5	5.5	5.5	149.2
132MTA6	7.5	7.5	7.0	7.5	7.0	6.5	216.4
160MZA6	7.5	7.5	7.0	7.5	7.0	6.3	324.8
160LYA6	9.3	9.3	9.3	9.3	9.3	9.3	422.8
160LZA6	11	11	11	11	11	11	422.8

6 Pole (Speed 1000 RPM)

Frame	150 Starts / hour			300 Starts / hour			Motor GD <sup>2</sup> kGm <sup>2</sup> x10 <sup>-3</sup>
	25% CDF	40% CDF	60% CDF	25% CDF	40% CDF	60% CDF	
	kW	kW	kW	kW	kW	kW	
80ZAA6	0.37	0.37	0.33	0.33	0.33	0.3	7.88
80ZBA6	0.55	0.55	0.5	0.5	0.5	0.45	9.88
90SAA6	0.75	0.75	0.7	0.7	0.7	0.65	12.72
90LBA6	1.1	1.1	0.9	0.9	0.9	0.8	19.12
100LAA6	1.5	1.5	1.3	1.3	1.1	1.1	26.92
100LBA6	1.8	1.8	1.6	1.8	1.5	1.3	37.72
112MAA6	2.2	2.2	2.0	2.0	2.0	1.8	56.72
112MBA6	3.0	3.0	2.7	2.7	2.2	2.0	74.8
132SZA6	3.0	3.0	2.7	2.7	2.7	2.2	94.0
132MYA6	3.7	3.7	3.3	3.3	3.3	3.0	118.0
132MZA6	5.5	5.5	5.0	5.0	5.0	4.5	149.2
132MTA6	7.5	7.0	6.3	6.5	6	5.5	216.4
160MZA6	5.8	5.3	5.0	-	-	-	324.8
160LYA6	9.3	9.3	9.3	9.3	8.2	7.8	422.8
160LZA6	11	11	9.8	9.8	8.5	8.0	422.8

**Note:** 1. Load GD<sup>2</sup> value should not be more than motor GD<sup>2</sup> value. 2. All motors suitable for an Ambient Temperature of 45 deg. C.

# Selection Chart

## Crane Duty Motors

(S2 / S3 / S4 Duty)

8 Pole (Speed 750 RPM)

Frame	60 Starts / hour			90 Starts / hour			Motor GD <sup>2</sup> kGm <sup>2</sup> x10 <sup>-3</sup>
	25% CDF	40% CDF	60% CDF	25% CDF	40% CDF	60% CDF	
	kW	kW	kW	kW	kW	kW	
90SAA8	0.37	0.37	0.37	0.37	0.37	0.37	12.72
90LBA8	0.55	0.55	0.55	0.55	0.55	0.55	19.12
100LAA8	0.75	0.75	0.75	0.75	0.75	0.68	26.88
100LBA8	1.1	1.1	1.1	1.1	1.1	1.0	63.72
112MAA8	1.5	1.5	1.5	1.5	1.5	1.2	66.8
132SZA8	2.2	2.2	2.2	2.2	2.2	2.2	118.0
132MZA8	3.0	3.0	3.0	3.0	3.0	3.0	150.8
160MYA8	3.7	3.7	3.7	3.7	3.7	3.3	358.0
160MZA8	5.5	5.5	5.5	5.5	5.5	5.0	478.0
160LZA8	7.5	7.5	7.5	7.5	7.5	7.0	600.8

8 Pole (Speed 750 RPM)

Frame	150 Starts / hour			300 Starts / hour			Motor GD <sup>2</sup> kGm <sup>2</sup> x10 <sup>-3</sup>
	25% CDF	40% CDF	60% CDF	25% CDF	40% CDF	60% CDF	
	kW	kW	kW	kW	kW	kW	
90SAA8	0.37	0.37	0.37	0.37	0.37	0.33	12.72
90LBA8	0.55	0.55	0.50	0.55	0.50	0.45	19.12
100LAA8	0.75	0.75	0.66	0.68	0.66	0.58	26.88
100LBA8	1.1	1.1	1.0	1.0	0.8	0.7	63.72
112MAA8	1.5	1.5	1.2	1.5	1.2	1.0	66.8
132SZA8	2.2	2.2	2.0	2.0	1.8	1.5	118.0
132MZA8	3	3	2.6	2.8	2.2	1.8	150.8
160MYA8	3.3	3.3	3.0	3.0	2.5	2.0	358.0
160MZA8	5.0	5.0	4.5	4.0	3.5	3.0	478.0
160LZA8	7.5	7.0	6.5	6.0	5.5	5.0	600.8

**Note:** 1. Load GD<sup>2</sup> value should not be more than motor GD<sup>2</sup> value. 2. All motors suitable for an Ambient Temperature of 45 deg. C.

# Brake Motors



## Introduction

Brake Motor is combination of an AC Induction Motor and Electromagnetic DC brake. DC supply is fed to the brake from a rectifier unit installed in the motor terminal box.

The brake is disc type and is mounted on the motor shaft. The brake is 'Fail proof Type' i.e. brake comes into action and stops the driven equipment instantly when the power to the motor is switched off or / if power fails.

The supply to the rectifier is fed from any two terminals of the main terminal box. Havells with its AEG technology, state-of-art plant and automatic processing can offer zero-defect Brake Motors in frames 63 to 160, in 2P, 4P, 6P and 8P versions.

## Operation

Under 'OFF' power condition Brake springs keep the Brake Liner pressed against the mounting flange thus preventing the rotation of the motor shaft. When power is switched on, the Brake coil gets energized through the Rectifier unit. It instantly attracts the armature disc by overcoming the spring force. This results in releasing of the brake rotor allowing the motor to rotate.

In the event of power failure / switch of mode, the brake coil gets de-energised. This results in the springs pressing the brake liner against mounting flange, i.e. returning armature disc to its original position. This results in instantaneous braking of rotor. Fail safe condition is thus ensured.

## Applicable Standard

IS 325  
IEC 34  
BS 4999  
IS 1231  
IS 2223

## Special Features

- The brake motors are simple, rugged & easy for maintenance.
- No separate DC supply is required as the rectifier is provided, which gives the required DC voltage for energisation of the brake.

- The rectifier is mounted inside the main terminal box so no separate terminal box required.
- Special brake liner is used which ensures, the braking torque value remains quite stable through out the use.

## General guidelines for selection of suitable brake model:

The brakes are rated by torque & selection of suitable model can be made by calculating the required torque, rating or the brake & then matching it with static torque.

Torque (Nm) =  $9550 \times (\text{KW/RPM}) \times \text{Safety Factor (SF)}$  where  
KW-Kilowatts of motor,  
RPM-Speed of motor,  
SF-Safety Factor

## Applications

Brake Motors are used for numerous applications.

A few of them are listed below:

- Textile machinery
- Machine Tools
- Printing Machine
- Cranes and Hoists
- Material Handling Equipments
- Leather Processing Machines
- Cable Reeling Drums
- Rolling Mills
- Elevators
- Conveyers, etc.

## Bearing Details

Frame Size	Bearing Sizes (C3 Clearance)	
	DE	NDE
63	6202 - 2Z	6202 - 2Z
71	6203 - 2Z	6203 - 2Z
80	6204 - 2Z C3	6204 - 2Z C3
90S, 90L	6205 - 2Z C3	6205 - 2Z C3
100L	6206 - 2Z C3	6206 - 2Z C3
112M	6306 - 2Z C3	6306 - 2Z C3
132S, 132M	6208 - 2Z C3	6208 - 2Z C3
160M, 160L	6309 - 2Z C3	6309 - 2Z C3

## Terms to be incorporated while placing an enquiry:

- Application detail
- Motor power & speed
- Brake size / required braking torque
- Mounting
- No. of start/stops per hour
- Duty cycle

## DC Brake Motors:

Voltage	:	415V +/-10%
Frequency	:	50Hz +/-5%
Combined Variation	:	+/-10%
Ambient Temp.	:	50°C
Duty	:	S1
Mounting	:	B3, B5, B14 & B35
Ins. Class	:	F
Temp. Rise	:	B
Protection	:	IP55

# Performance Table - For Brake Part

## Selection Chart

KW	HP	Type	Rated Speed	Torque Mn	Brake Torque Nm	Safety Factor	KW	HP	Type	Rated Speed	Torque Mn	Brake Torque Nm	Safety Factor
0.12	0.16	MHBY63ZAA4	1350	0.85	5	5.9	2.2	3	MHBY90LCA2	2860	7.35	16	2.2
		MHBY71ZAA8	670	1.71	5	2.9			MHBY100LAA4	1435	14.64	35	2.4
0.18	0.25	MHBY63ZAA2	2790	0.62	5	8.1			MHBY112MAA6	940	22.35	60	2.7
		MHBY63ZBA4	1330	1.29	5	3.9			MHBY132SZA8	710	29.59	60	2
		MHBY71ZAA6	850	2.02	5	2.5	3	4	MHBY100LAA2	2860	10.02	35	3.5
		MHBY80ZAA8	680	2.53	10	4			MHBY100LBA4	1425	20.11	60	3
0.25	0.33	MHBY63ZBA2	2790	0.86	5	5.8			MHBY132SZA6	950	30.16	80	2.7
		MHBY71ZAA4	1340	1.78	5	2.8			MHBY132MZA8	710	40.35	80	2
		MHBY71ZBA6	870	2.74	5	1.8	3.7	5	MHBY100LCA2	2865	12.33	35	2.8
		MHBY80ZAA8	680	3.51	10	2.8			MHBY112MAA4	1430	24.71	60	2.4
0.37	0.5	MHBY71ZAA2	2820	1.25	5	4			MHBY132SYA6	950	37.19	80	2.2
		MHBY71ZBA4	1370	2.58	5	1.9			MHBY160MYA8	700	50.48	150	3
		MHBY80ZAA6	910	3.88	10	2.6	5.5	7.5	MHBY132SYA2	2890	18.17	60	3.3
		MHBY90SAA8	680	5.2	16	3.1			MHBY132SZA4	1430	36.73	80	2.2
0.55	0.75	MHBY71ZBA2	2830	1.86	10	5.4			MHBY132MZA6	950	55.29	150	2.7
		MHBY80ZAA4	1400	3.75	10	2.7			MHBY160MZA8	720	72.95	150	2.1
		MHBY80ZBA6	910	5.77	10	1.7	7.5	10	MHBY132SZA2	2880	24.87	60	2.4
		MHBY90LBA8	680	7.72	16	2.1			MHBY132MZA4	1440	49.74	150	3
0.75	1	MHBY80ZAA2	2840	2.52	10	4			MHBY160MZA6	970	73.84	150	2
		MHBY80ZBA4	1410	5.08	10	2			MH BY160LZA8	710	100.88	260	2.6
		MHBY90SAA6	910	7.87	16	2	9.3	12.5	MHBY132MRA2	2880	30.84	80	2.6
		MHBY100LAA8	690	10.38	35	3.4			MHBY160MYA4	1460	60.83	150	2.5
1.1	1.5	MHBY80ZBA2	2810	3.74	10	2.7			MHBY160LYA6	960	92.52	260	2.8
		MHBY90SAA4	1400	7.5	16	2.1	11	15	MHBY160MVA2	2940	35.73	80	2.2
		MHBY90LBA6	908	11.57	35	3			MHBY160MXA4	1460	71.95	150	2.1
		MHBY100LBA8	690	15.22	35	2.3			MHBY160LZA6	960	109.43	260	2.4
1.5	2	MHBY90SAA2	2830	5.06	16	3.2	15	20	MHBY160MXA2	2940	48.72	150	3.1
		MHBY90LBA4	1400	10.23	35	3.4			MHBY160LXA4	1460	98.12	260	2.6
		MHBY100LAA6	930	15.4	35	2.3	18.5	25	MHBY160LXA2	2950	59.89	150	2.5
		MHBY112MAA8	696	20.58	60	2.9							

### Break Coil Connection Diagram:

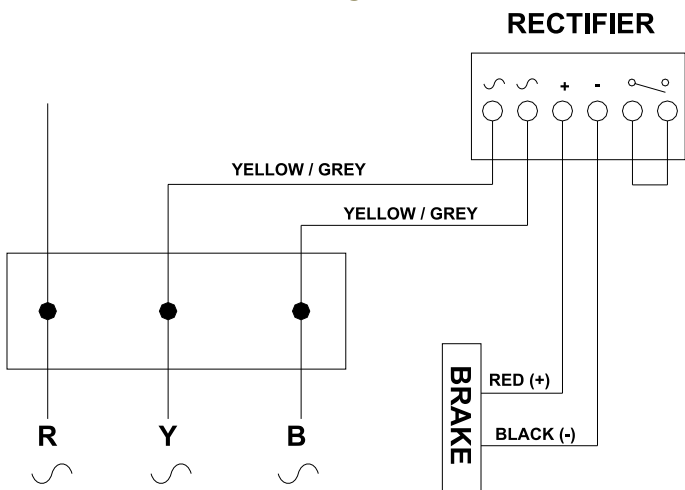

The Motor must never be switched ON unless the brake is energized and the brake should never be De-energised when the motor is ON. The interlocking of two contactors is Absolutely Necessary.

### Note:

1. Other higher braking torque values can be given for special applications.
2. For performance details of motor part, please refer latest standard motor catalogue.

## General Arrangement / Dimensional Drawing - Foot Mounted (B3) Brake Motor

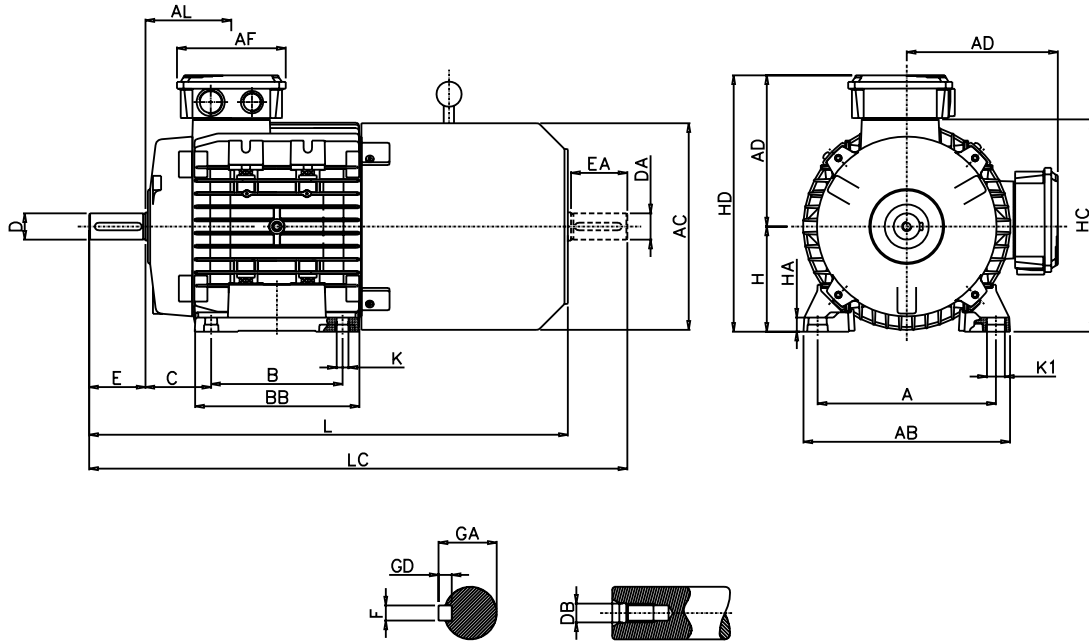

Frame	D/DA	E/EA	AD (2)	AL	AF	F/FA h10	GD	L	LC	GA/ GC	DB (3)	AC	H	A	B	C	K(1)	AB	BB	HD (2)	HC	HA	K1	BA	AA
63	11 j6	23	96.5	66	92	4	4	290	310	12.5	M4	123	63	100	80	40	7	119	100	159.5	119.5	8	11	29	30
71	14 j6	30	111	69	92	5	5	331	358	16	M5	139	71	112	90	45	8	135	109	182	142	8	11	29	31
80	19 j6	40	139	79	110	6	6	377	419	21.5	M6	155.6	80	125	100	50	10	153	125	219	162	9.5	14	28.5	35
90S	24 j6	50	148	84.5	110	8	7	421	472	27	M8	176.6	90	140	100	56	10	170	150	238	181	11	15	28/53	37
90L	24 j6	50	148	84.5	110	8	7	421	472	27	M8	176.6	90	140	125	56	10	170	150	238	181	11	15	28/53	37
100L	28 j6	60	155	91	110	8	7	484	546	31	M10	192	100	160	140	63	11	192	166	255	198	12	17	38	44
112M	28 j6	60	171	91.5	110	8	7	512	575	31	M10	221	112	190	140	70	12.5	220	175	283	226	15	19	46	48.5
132S	38 k6	80	195	100	133	10	8	567	642	41	M12	248	132	216	140	89	12	256	180	327	261	17	20	45	59
132M	38 k6	80	195	120	133	10	8	622	698	41	M12	248	132	216	178	89	12	256	218	327	261	17	20	45	59
132M	38 k6	80	195	120	133	10	8	640	733	41	M12	248	132	216	178	89	12	256	218	327	261	17	20	45	59
160M	42 k6	110	240.5	146	150	12	8	750	853	45	M16	317	160	254	210	108	14	320	270	400.5	317	23	18	65	76
160L	42 k6	110	240.5	168	150	12	8	810	913	45	M16	317	160	254	254	108	14	320	310	400.5	317	23	18	65	76



## General Arrangement / Dimensional Drawing - Flange Mounted (B5) Brake Motor

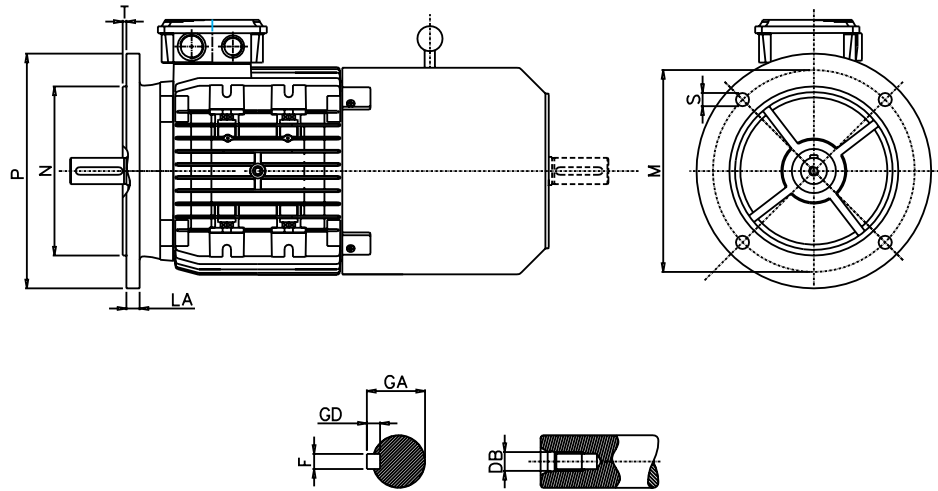

Frame	D/DA	E/EA	AD (2)	AL	AF	F/FA h10	GD	L	LC	GA/ GC	DB (3)	AC	P	N	LA	M	T	S
63	11 j6	23	96.5	66	92	4	4	290	310	12.5	M4	123	140	95	3	9.5	115	8
71	14 j6	30	111	69	92	5	5	331	358	16	M5	139	160	110	3.5	9.5	130	10
80	19 j6	40	139	79	110	6	6	377	419	21.5	M6	155.6	200	130	3.5	11.5	165	10
90S	24 j6	50	148	84.5	110	8	7	421	472	27	M8	176.6	200	130	3.5	11.5	165	12
90L	24 j6	50	148	84.5	110	8	7	421	472	27	M8	176.6	200	130	3.5	11.5	165	12
100L	28 j6	60	155	91	110	8	7	484	546	31	M10	192	250	180	4	14	215	14
112M	28 j6	60	171	91.5	110	8	7	512	575	31	M10	221	250	180	4	14	215	14
132S	38 k6	80	195	100	133	10	8	567	642	41	M12	248	300	230	4	14	265	14
132M	38 k6	80	195	120	133	10	8	622	698	41	M12	248	300	230	4	14	265	14
132M	38 k6	80	195	120	133	10	8	640	733	41	M12	248	300	230	4	14	265	14
160M	42 k6	110	240.5	146	150	12	8	750	853	45	M16	317	350	250	5	18	300	15
160L	42 k6	110	240.5	168	150	12	8	810	913	45	M16	317	350	250	5	18	300	15

## General Arrangement / Dimensional Drawing - Face Mounted (B14) Brake Motor

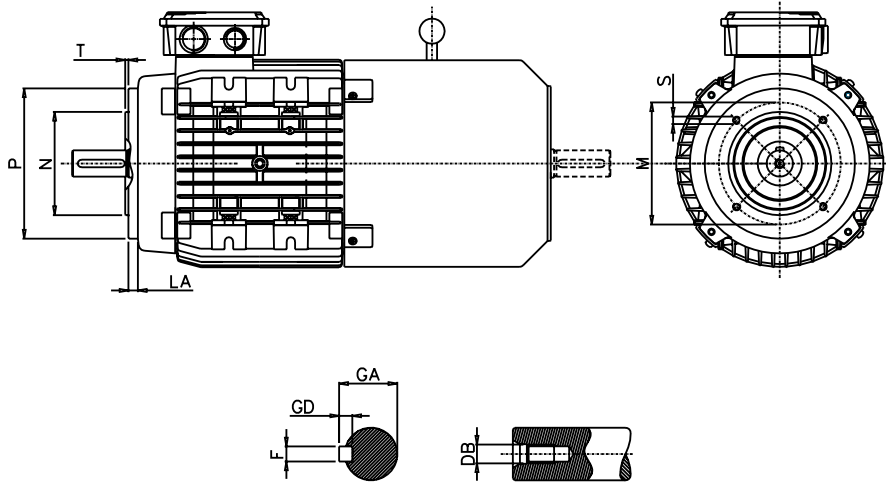

Frame	D/DA	E/EA	AD (2)	AL	AF	F/FA h10	GD	L	LC	GA/ GC	DB (3)	AC	P	N	LA	M	T	S
63	11 j6	23	96.5	66	92	4	4	290	310	12.5	M4	123	90	60	8.5	75	2.5	M5
71	14 j6	30	111	69	92	5	5	331	358	16	M5	139	105	70	7.6	85	2.5	M6
80	19 j6	40	139	79	110	6	6	377	419	21.5	M6	155.6	120	80	9.5	100	3	M6
90S	24 j6	50	148	84.5	110	8	7	421	472	27	M8	176.6	140	95	9	115	3	M8
90L	24 j6	50	148	84.5	110	8	7	421	472	27	M8	176.6	140	95	9	115	3	M8
100L	28 j6	60	155	91	110	8	7	484	546	31	M10	192	160	110	10	130	3.5	M8
112M	28 j6	60	171	91.5	110	8	7	512	575	31	M10	221	160	110	10	130	3.5	M8
132S	38 k6	80	195	100	133	10	8	567	642	41	M12	248	200	130	23	165	3.5	M10
132M	38 k6	80	195	120	133	10	8	622	698	41	M12	248	200	130	23	165	3.5	M10
132M	38 k6	80	195	120	133	10	8	640	733	41	M12	248	200	130	23	165	3.5	M10
160M	42 k6	110	240.5	146	150	12	8	750	853	45	M16	317	250	180	20	215	4	M12
160L	42 k6	110	240.5	168	150	12	8	810	913	45	M16	317	250	180	20	215	4	M12

## Inverter Duty Motors

(With Forced Cooling)



## Crane Duty Motors



## Brake Motors



### REGIONAL & BRANCH OFFICES:

**NORTH - REGIONAL OFFICE: Corporate Office:** QRG Towers, 2D, Sector-126, Expressway, Noida-201304, Tel: 0120-3331000, **Delhi:** Tel: 011-47676700, 23888200, **Chandigarh:** Tel: 0172-4232400-401, **Dehradun:** Tel: 0135-6670202, **Noida / Haryana:** Tel: 0120-3331000, **Ludhiana:** Tel: 0161-4676000 / 24, **Jammu:** Tel: 0191-2478330, 2479330, **Sri Nagar:** Tel: 0194-2490431, **Jaipur:** Tel: 0141-3914645, 3988210 **Jodhpur:** Tel: 0291-9214201640 / 45, **Lucknow:** Tel: 0522-6672100, **Kanpur:** Tel: 0512-6710400, 6710409

**EAST - REGIONAL OFFICE: Kolkata:** ICC Tower, 5th Floor, 4 India Exchange Place, Kolkata-700001, Tel: 033-40129851/ 52, **Bhubaneshwar:** Tel: 0674-6668101/102/103/104, **Guwahati:** Tel: 0361-2134521, 2458923, 2460355, **Siliguri:** Tel: 0353-2525907, **Ranchi:** 0651-2244861, 2244862, 2244864, 2244868, 2244869, **Jamshedpur:** Tel: 0657-6542492, 09234369436, **Patna:** Tel: 0612-2207221, 2207222, 2207223, 2655518

**WEST - REGIONAL OFFICE: Mumbai:** 1271, Solitaire Corporate Park, Bldg. No. 12, 7th Floor, Andheri - Ghatkopar Link Road, Chakala, Andheri (East), Mumbai- 400093. Ph.: 022 - 67298600-602, **Ahmedabad:** Tel: 079-40061111, 40507700, 40507777, **Indore:** Tel: 0731-2572340-41, 4009998 (Airtel), **Rajkot:** Tel: 0281-2481112, 2921212, **Nagpur:** Tel: 0712-2240932, 2242692, 2242699, **Pune:** Tel: 020-64016413 / 14, **Raipur:** Tel: 0771-4243400 / 01, **Surat:** Tel: 0261-2350137, 9979890137, **Jabalpur:** Tel: 0761-4064491

### SOUTH - REGIONAL OFFICE:

**Chennai:** Sigapi Achi Building, No. 18 / 3, 6th Floor, Rukmani Lakshminpathy Road, Egmore, Chennai-600008, Tel: 044-42280600, 605, **Bangalore:** Tel: 080-49075000, **Coimbatore:** Tel: 0422-4550200, 2305199, 2306199, **Hyderabad:** Tel: 040-27533372, 27533355, 27533632, 66320407/0408/6401/6402, **Kochi:** Tel: 0484-4099000, **Vishakapatnam:** Tel: 0891-6514339, **Vizag:** Tel: 0891-6514339, **Vijayawada:** Tel: +91-9247058847/57, **Calicut:** 0495-4019194, **Madurai:** 0452-4267022, **Trivandrum:** 0471-4015323, **Hubli:** 0836-4248600, **Trichy:** 09944460160

Representative Offices: • Goa • Solapur • Gwalior • Kathmandu • Bhopal

Scan the QR Code  
to download  
Havells mCatalogue



## Havells India Ltd.

QRG Towers, 2D, Sector -126, Expressway, Noida - 201 304 (UP), Ph. +91-120-3331000,

E-mail: marketing@havells.com, www.havells.com

Consumer Care No.: 1800 11 0303, 1800 103 1313 (All Connections), 011-4166 0303 (Landline)

Join us on Facebook at www.facebook.com/havells and share your ways to save the planet!

CIN - L31900DL1983PLC016304.



# HAVELLS